

LED INCASSO QUADRO 220V 3W 250LM CODICE PRODOTTO 400789

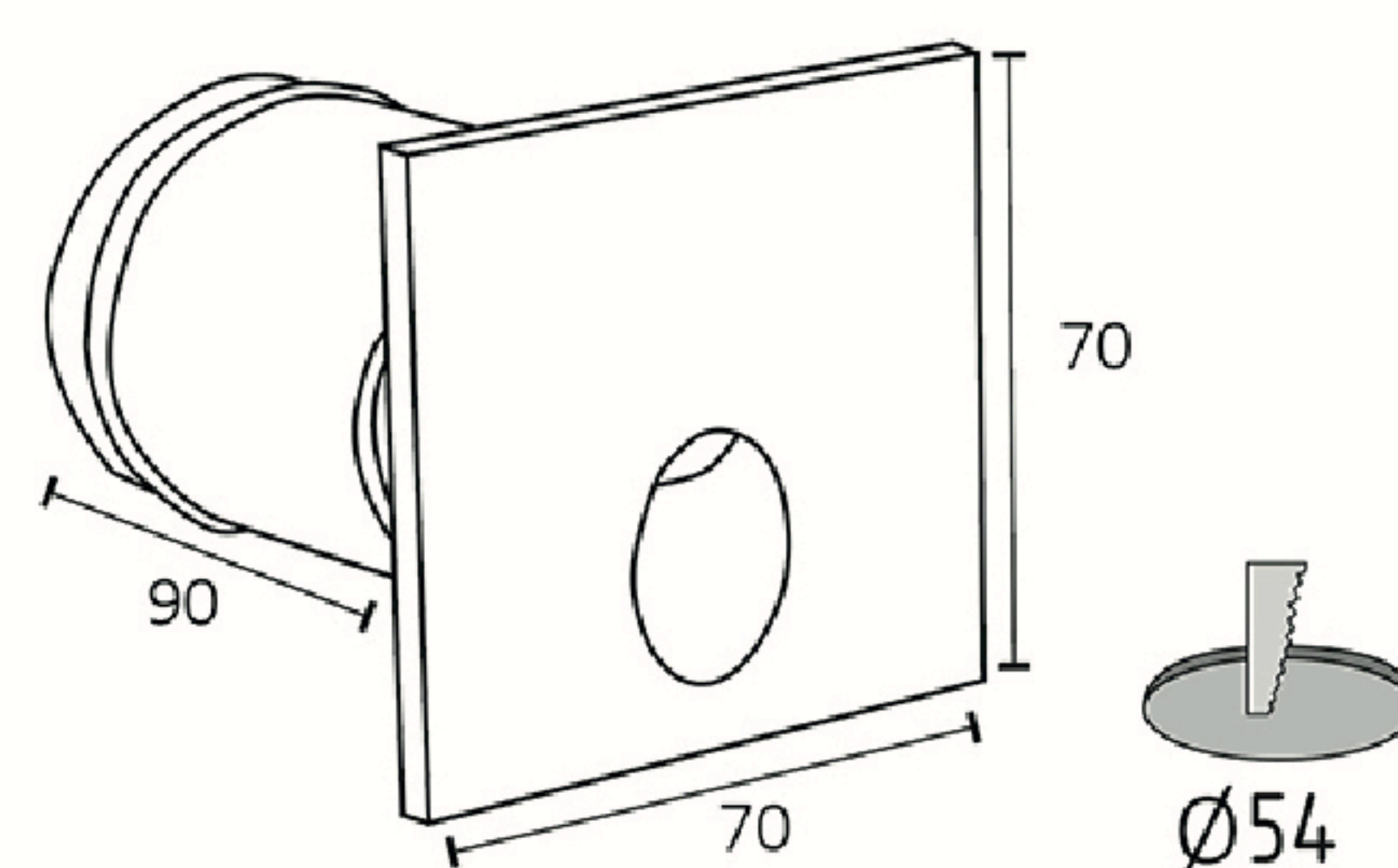

Materiale/Housing material	Alluminio
Colore/Colour	Alluminio - Bianco
Ambiente di utilizzo/Environment	Esterno
Certificazione/Certifications	CE
Lumen/Lumen	250
Efficacia luminosa/Luminaire efficacy (lm/W)	--
Gradi Kelvin/Kelvin degrade (K)	3000K/4200K/6500K
Angolo/Beam angle	--
Consumo/Power	3W
Tensione/Voltage	220-240V 50/60Hz
Classe sicurezza/Isolation class	1 Classe
Classe protezione/Protection degree	IP 54
Classe energetica/Energy label	G